



## Up to Category 4, EN 954-1 PNOZ X3.1



Safety relay for monitoring E-STOP pushbuttons and safety gates.

### Approvals

	PNOZ X3.1
	◆
	◆
	◆

### Unit features

- ▶ Positive-guided relay outputs:
  - 3 safety contacts (N/O), instantaneous
  - 1 auxiliary contact (N/C), instantaneous
- ▶ 1 semiconductor output
- ▶ Connection options for:
  - E-STOP pushbutton
  - Safety gate limit switch
  - Reset button
- ▶ LED indicator for:
  - Switch status channel 1/2
  - Supply voltage
  - Input circuits
- ▶ Semiconductor output signals:
  - Switch status channel 1/2
- ▶ See order reference for unit types

### Safety features

The relay conforms to the following safety criteria:

- ▶ The circuit is redundant with built-in self-monitoring.
- ▶ The safety function remains effective in the case of a component failure.
- ▶ The correct opening and closing of the safety function relays is tested automatically in each on-off cycle.
- ▶ The transformer is short circuit-proof. An electronic fuse is used on a DC supply.

### Unit description

The safety relay meets the requirements of EN 60204-1 and IEC 60204-1 and may be used in applications with

- ▶ E-STOP pushbuttons
- ▶ Safety gates

### Block diagram

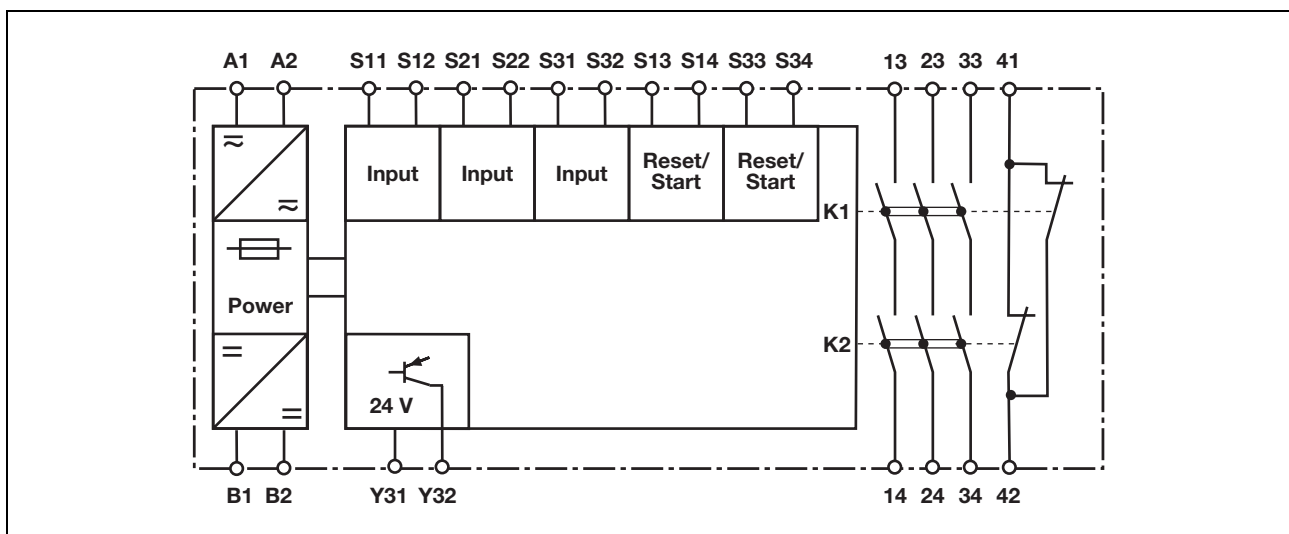

## Up to Category 4, EN 954-1 PNOZ X3.1

### Function description

- ▶ Single-channel operation: no redundancy in the input circuit, earth faults in the reset circuit are detected.
- ▶ Dual-channel operation with detection of shorts across contacts: redundant input circuit, detects
  - earth faults in the reset and input circuit,
  - short circuits in the input circuit and, with a monitored reset, in the reset circuit too,
  - shorts between contacts in the input circuit.
- ▶ Automatic start: Unit is active once the input circuit has been closed.
- ▶ Monitored reset: Unit is active once the input circuit is closed and once the reset circuit is closed after the waiting period has elapsed (see technical details).
- ▶ Increase in the number of available contacts by connecting contact expander modules or external contactors/relays.

### Timing diagram

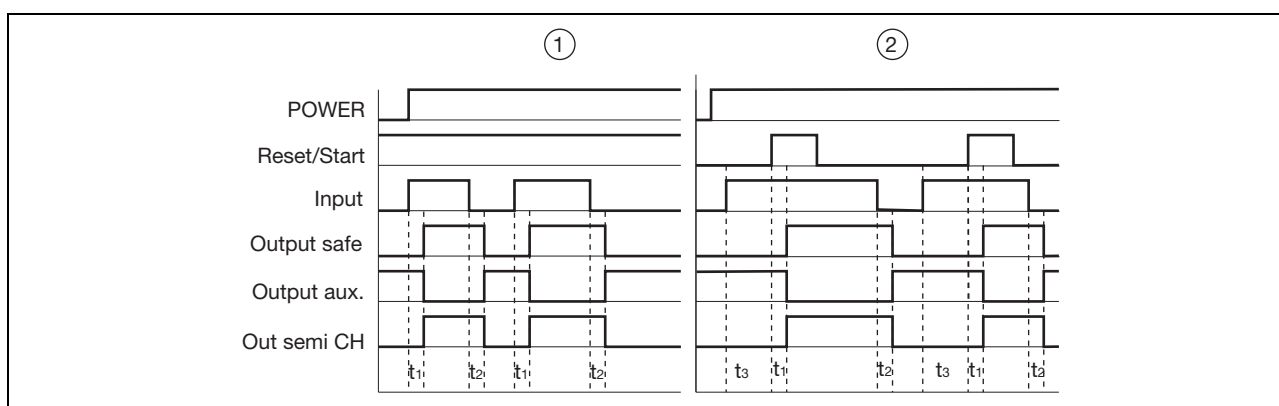

### Key

- ▶ Power: Supply voltage
- ▶ Reset/start: Reset circuit S13-S14, S33-S34
- ▶ Input: Input circuits S11-S12, S21-S22, S31-S32
- ▶ Output safe: Safety contacts 13-14, 23-24, 33-34
- ▶ Output aux.: Auxiliary contacts 41-42
- ▶ Out semi CH: Semiconductor output switch status channel 1/2
- ▶ ①: Automatic reset
- ▶ ②: Monitored reset
- ▶ t<sub>1</sub>: Switch-on delay
- ▶ t<sub>2</sub>: Delay-on de-energisation
- ▶ t<sub>3</sub>: Waiting period

### Wiring

#### Please note:

- ▶ Information given in the “Technical details” must be followed.
- ▶ Outputs 13-14, 23-24, 33-34 are safety contacts, output 41-42 is an auxiliary contact (e.g. for display).
- ▶ To prevent contact welding, a fuse should be connected before the output contacts (see technical details).
- ▶ Calculation of the max. cable runs  $l_{max}$  in the input circuit:

$$l_{max} = \frac{R_{lmax}}{R_l / km}$$

$R_{lmax}$  = max. overall cable resistance (see technical details)

$R_l / km$  = cable resistance/km

- ▶ Use copper wire that can withstand 60/75 °C.

- ▶ Sufficient fuse protection must be provided on all output contacts with capacitive and inductive loads.

## Up to Category 4, EN 954-1 PNOZ X3.1

### Preparing for operation

► Supply voltage

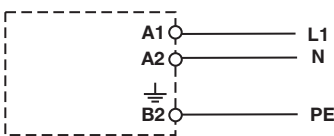
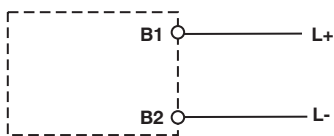

Supply voltage	AC	DC
		

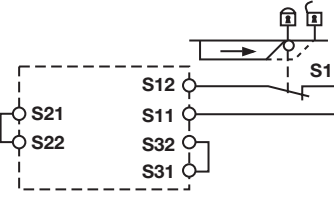
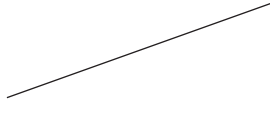
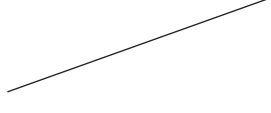
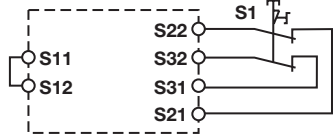
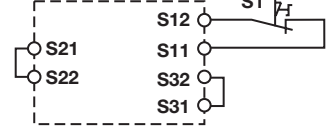
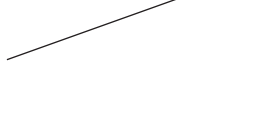
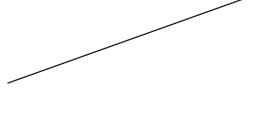
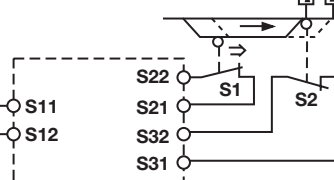
► Input circuit

Input circuit	Single-channel	Dual-channel
E-STOP <b>without</b> detection of shorts across contacts		
E-STOP <b>with</b> detection of shorts across contacts		
Safety gate <b>without</b> detection of shorts across contacts		
Safety gate <b>with</b> detection of shorts across contacts		

## Up to Category 4, EN 954-1 PNOZ X3.1

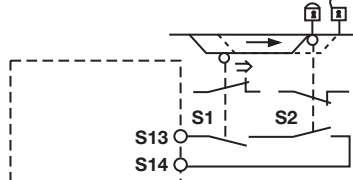
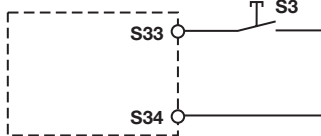
### ▶ Reset circuit

Reset circuit	E-STOP wiring (single-channel) Safety gate (single-channel)	E-STOP wiring (dual-channel) Safety gate (dual-channel)
Automatic reset		
Monitored reset		

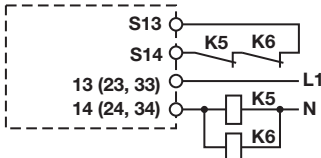
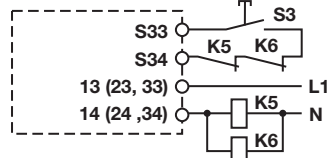

### ▶ Feedback loop

Feedback loop	Automatic reset	Monitored reset
Contacts from external contactors		

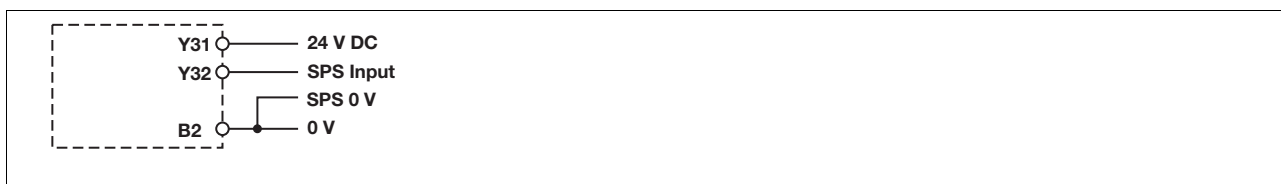
### ▶ Semiconductor output



### ▶ Key

S1/S2	E-STOP pushbutton/ safety gate switch
S3	Reset button
	Switch operated
	Gate open
	Gate closed

## Up to Category 4, EN 954-1 PNOZ X3.1

### Terminal configuration

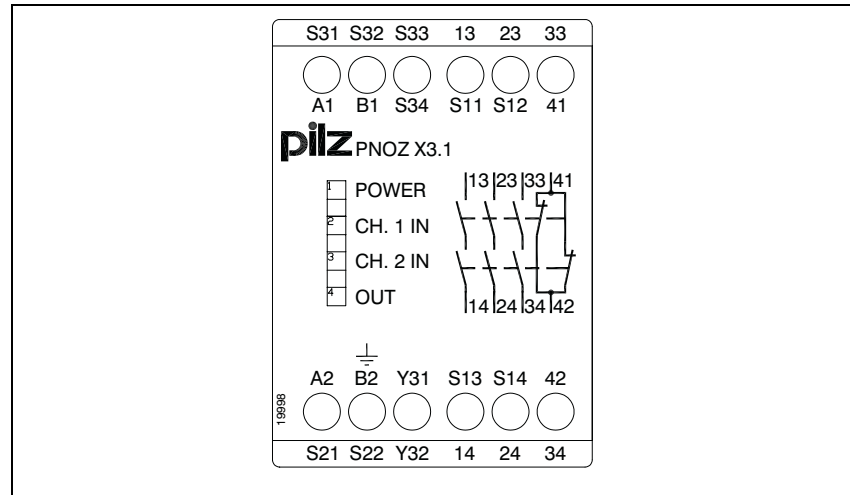

### Installation

- ▶ The safety relay should be installed in a control cabinet with a protection type of at least IP54.
- ▶ Use the notch on the rear of the unit to attach it to a DIN rail.
- ▶ Ensure the unit is mounted securely on a vertical DIN rail (35 mm) by using a fixing element (e.g. retaining bracket or an end angle).

### Dimensions

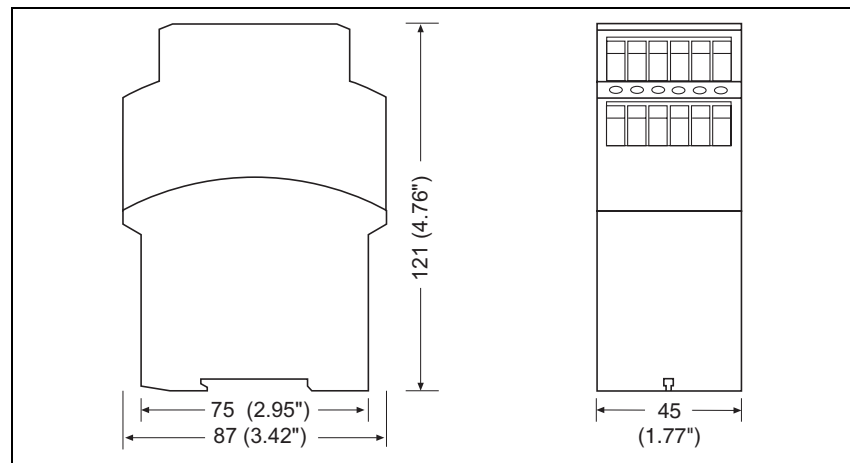

## Up to Category 4, EN 954-1 PNOZ X3.1

### Notice

This data sheet is only intended for use during configuration. For installation and operation, please refer to the operating instructions supplied with the unit.

### Service life graph

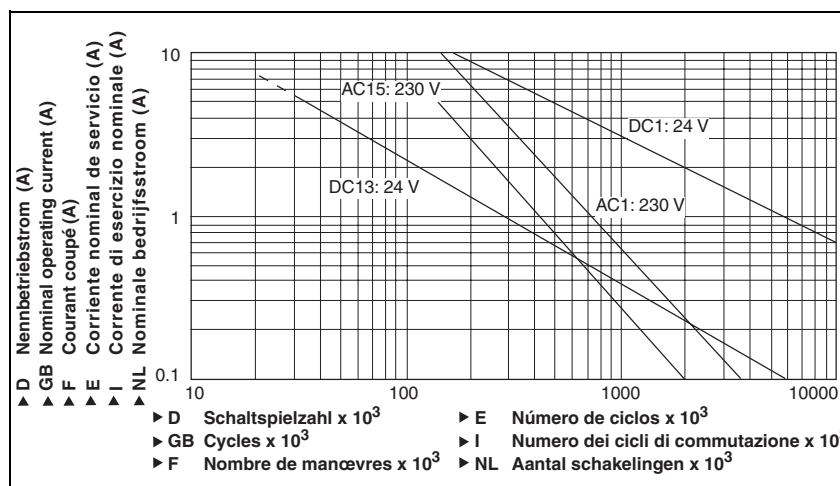

### Technical details

#### Electrical data

Supply voltage	
Supply voltage U <sub>B</sub> AC	<b>230 V, 240 V</b>
Supply voltage U <sub>B</sub> DC	<b>24 V</b>
Voltage tolerance	<b>-15 %/+10 %</b>
Power consumption at U <sub>B</sub> AC	<b>5.0 VA</b>
Power consumption at U <sub>B</sub> DC	<b>2.5 W</b>
Frequency range AC	<b>50 - 60 Hz</b>
Residual ripple DC	<b>160 %</b>
Voltage and current at input circuit DC: <b>24.0 V</b>	<b>50.0 mA</b>
reset circuit DC: <b>24.0 V</b>	<b>35.0 mA</b>
feedback loop DC: <b>24.0 V</b>	<b>20.0 mA</b>
Output contacts in accordance with <b>EN 954-1</b> Category <b>4</b>	Safety contacts (N/O): <b>3</b> Auxiliary contacts (N/C): <b>1</b>
Utilisation category in accordance with <b>EN 60947-4-1</b>	
Safety contacts: AC1 at <b>240 V</b>	I <sub>min</sub> : <b>0.01 A</b> , I <sub>max</sub> : <b>8.0 A</b> P <sub>max</sub> : <b>2000 VA</b>
Safety contacts: DC1 at <b>24 V</b>	I <sub>min</sub> : <b>0.01 A</b> , I <sub>max</sub> : <b>8.0 A</b> P <sub>max</sub> : <b>200 W</b>
Auxiliary contacts: AC1 at <b>240 V</b>	I <sub>min</sub> : <b>0.01 A</b> , I <sub>max</sub> : <b>8.0 A</b> P <sub>max</sub> : <b>2000 VA</b>
Auxiliary contacts: DC1 at <b>24 V</b>	I <sub>min</sub> : <b>0.01 A</b> , I <sub>max</sub> : <b>8.0 A</b> P <sub>max</sub> : <b>200 W</b>
Utilisation category in accordance with <b>EN 60947-5-1</b>	
Safety contacts: AC15 at <b>230 V</b>	I <sub>max</sub> : <b>5.0 A</b>
Safety contacts: DC13 at <b>24 V</b> (6 cycles/min)	I <sub>max</sub> : <b>6.0 A</b>
Auxiliary contacts: AC15 at <b>230 V</b>	I <sub>max</sub> : <b>5.0 A</b>
Auxiliary contacts: DC13 at <b>24 V</b> (6 cycles/min)	I <sub>max</sub> : <b>6.0 A</b>
Contact material	<b>AgSnO<sub>2</sub> + 0.2 µm Au</b>

## Up to Category 4, EN 954-1 PNOZ X3.1

<b>Electrical data</b>	
External contact fuse protection to <b>EN 60947-5-1</b>	
Blow-out fuse, quick	
Safety contacts:	<b>10 A</b>
Auxiliary contacts:	<b>10 A</b>
Blow-out fuse, slow	
Safety contacts:	<b>6 A</b>
Auxiliary contacts:	<b>6 A</b>
Circuit breaker 24 VAC/DC, characteristic B/C	
Safety contacts:	<b>6 A</b>
Auxiliary contacts:	<b>6 A</b>
Semiconductor outputs (short circuit proof)	<b>24.0 V DC, 20 mA</b>
External supply voltage	<b>24.0 V DC</b>
Voltage tolerance	<b>-20 %/+20 %</b>
Max. overall cable resistance $R_{lmax}$ input circuits, reset circuits	
single-channel at $U_B$ DC	<b>150 Ohm</b>
single-channel at $U_B$ AC	<b>180 Ohm</b>
dual-channel with detect. of shorts across contacts at $U_B$ DC	<b>15 Ohm</b>
dual-channel with detect. of shorts across contacts at $U_B$ AC	<b>30 Ohm</b>
<b>Times</b>	
Switch-on delay	
with automatic reset typ.	<b>250 ms</b>
with automatic reset max.	<b>500 ms</b>
with automatic reset after power on typ.	<b>280 ms</b>
with automatic reset after power on max.	<b>550 ms</b>
with monitored reset typ.	<b>35 ms</b>
with monitored reset max.	<b>50 ms</b>
Delay-on de-energisation	
with E-STOP typ.	<b>15 ms</b>
with E-STOP max.	<b>30 ms</b>
with power failure typ.	<b>50 ms</b>
with power failure max.	<b>70 ms</b>
Recovery time at max. switching frequency 1/s	
after E-STOP	<b>50 ms</b>
after power failure	<b>100 ms</b>
Waiting period with a monitored reset	<b>300 ms</b>
Min. start pulse duration with a monitored reset	<b>30 ms</b>
Simultaneity, channel 1 and 2	$\infty$
Supply interruption before de-energisation	<b>20 ms</b>
<b>Environmental data</b>	
EMC	<b>EN 60947-5-1, EN 61000-6-2</b>
Vibration in accordance with <b>EN 60068-2-6</b>	
Frequency	<b>10 - 55 Hz</b>
Amplitude	<b>0.35 mm</b>
Climatic suitability	<b>EN 60068-2-78</b>
Airgap creepage	<b>VDE 0110-1</b>
Ambient temperature	<b>-20 - 55 °C</b>
Storage temperature	<b>-40 - 85 °C</b>
Protection type	
Mounting (e.g. control cabinet)	<b>IP54</b>
Housing	<b>IP40</b>
Terminals	<b>IP20</b>
<b>Mechanical data</b>	
Housing material	
Housing	<b>PPO UL 94 V0</b>
Front	<b>ABS UL 94 V0</b>

## Up to Category 4, EN 954-1 PNOZ X3.1

### Mechanical data

Max. cross section of external conductors with screw terminals

1 core flexible **0.20 - 4.00 mm<sup>2</sup> , 24 - 10 AWG**

2 core, same cross section, flexible:

with crimp connectors, without insulating sleeve **0.20 - 2.50 mm<sup>2</sup> , 24 - 14 AWG**

without crimp connectors or with TWIN crimp connectors **0.20 - 2.50 mm<sup>2</sup> , 24 - 14 AWG**

Torque setting with screw terminals **0.60 Nm**

Dimensions

Height **87.0 mm**

Width **45.0 mm**

Depth **121.0 mm**

Weight **375 g**

The standards current on **09/01** apply.

### Max. continuous current

Number of contacts	$I_{max}$ (A) at $U_B$ DC	$I_{max}$ (A) at $U_B$ AC
1	<b>8.00 A</b>	<b>8.00 A</b>
2	<b>8.00 A</b>	<b>7.50 A</b>
3	<b>7.00 A</b>	<b>6.50 A</b>

### Order reference

Type	Features	Terminals	Order no.
PNOZ X3.1	230 VAC 24 VDC	Screw terminals	774 321
PNOZ X3.1	240 VAC 24 VDC	Screw terminals	774 322